



Description

Designed for use on small rooms or extensions, provides temperature controlled mixed water to underfloor heating systems with a heat output of up to 3kW, satisfying underfloor heating areas up to 40 sqm. UFH control pack for providing temperature controlled mixed water in single room applications to an underfloor heating system with a heat output up to 3Kw. The pump is pre-wired in conjunction with a flow temperature thermostat and mains connection cable and has provision to connect a room stat. The unit has integral ball valves for connecting/isolating the primary heating system, an adjustable thermostatic blending valve and an 'A' rated 6 meter circulating pump all secured to a fixing bracket with anti-vibration mountings for silent operation. G'2"tappings are provided for use with any adaptors to connect the unit to the underfloor heating loop or manifolds.

- Compact bolt on unit providing quick and simple installation
- Provides mixed temperature water to underfloor heating systems with a heat output up to 3Kw
- Easy set up with adjustable temperature range
- Controls flow temperatures to $\pm 2^{\circ}\text{C}$ even with fluctuating temperature and flow from the boiler

Installation

The Single room UFH control pack is designed for wall fixing and ideally should be mounted in a horizontal position with the electrical connection box uppermost. However, it can also be mounted vertical to pump up or down if desired. Provision should be made to vent air to protect pump from cavitation. The unit must not be floor mounted or in any position that inclines the pump shaft vertical. Refer to the pump installation leaflet enclosed. Choose the location for the unit ensuring adequate clearance and accessibility for pipe work and any subsequent maintenance. This is particularly important if enclosed within a cupboard space for example. Locate the unit on the wall and mark the hole fixing positions through the bracket. Take care to protect any electrical equipment and cables during handling.

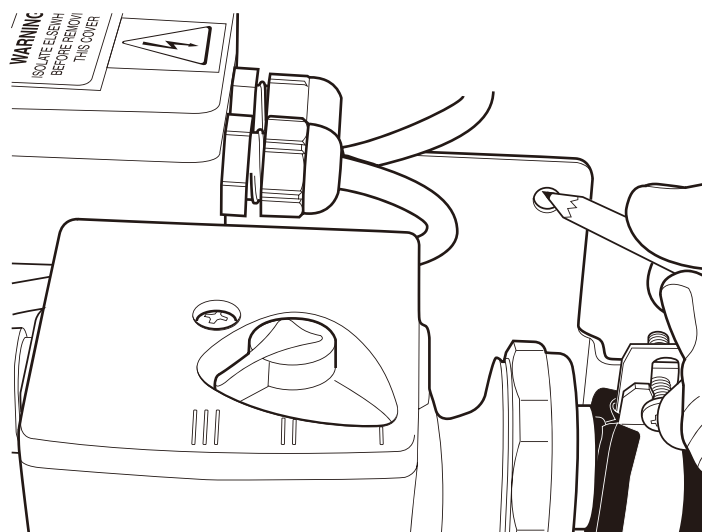

Remove the unit and drill (8mm masonry drill) and plug the holes. Align and secure the unit to the wall with the screws provided. The unit is now ready for connecting to the primary heating supply and underfloor heating loops. If appropriate the unit can be connected to the underfloor heating loop(s), filled and pressurised via the integral ball valves and then locked off for floor screeding before making the boiler connection.

Maintenance

The performance of the Heatguard UFH blending valve should be checked on an annual basis and verified against the original installation performance. If the water or installation conditions are more severe this check should be carried out more frequently.

If water conditions or installation conditions are severe and the valve is sluggish in operation, it is possible that there is a build up of scale or debris within the valve, it can then be stripped down and cleaned very easily:

1. Isolate the hot flow and cold return supplies and remove the valve from the installation. Make note of the orientation of the parts as they are removed so that they can be re-assembled in the correct manner.
2. To clean the internals of the main valve body, first remove the cap using an allen key, then remove the plastic locking ring, then finally carefully remove the valve headwork by unscrewing the large hex nut.
3. Slide the piston and thermostat assembly out of the valve body and clean all internal surfaces and 'O' rings with clean running water.
4. Using a WRAS approved silicone based waterproof grease, lightly lubricate the 'O-ring in the body and the external surface of the piston.
5. After cleaning, re-assemble the Heatguard UFH blending valve. Reset and test the valve.

Connection layout

All wiring should be undertaken by a qualified installer and conform to IEE regulations. To comply with IEE regulations the pump on the unit is provided with an earth connection via the connection box. A fused spur should be provided adjacent to the unit. The mains cable should be connected to the spur and fused at 3 amps.

If fitting a room thermostat, fix in a position on the wall as recommended in the manufacturer's instructions. If a room thermostat is fitted, remove the link between the terminals as indicated on the wiring diagram.

WIRING DIAGRAM

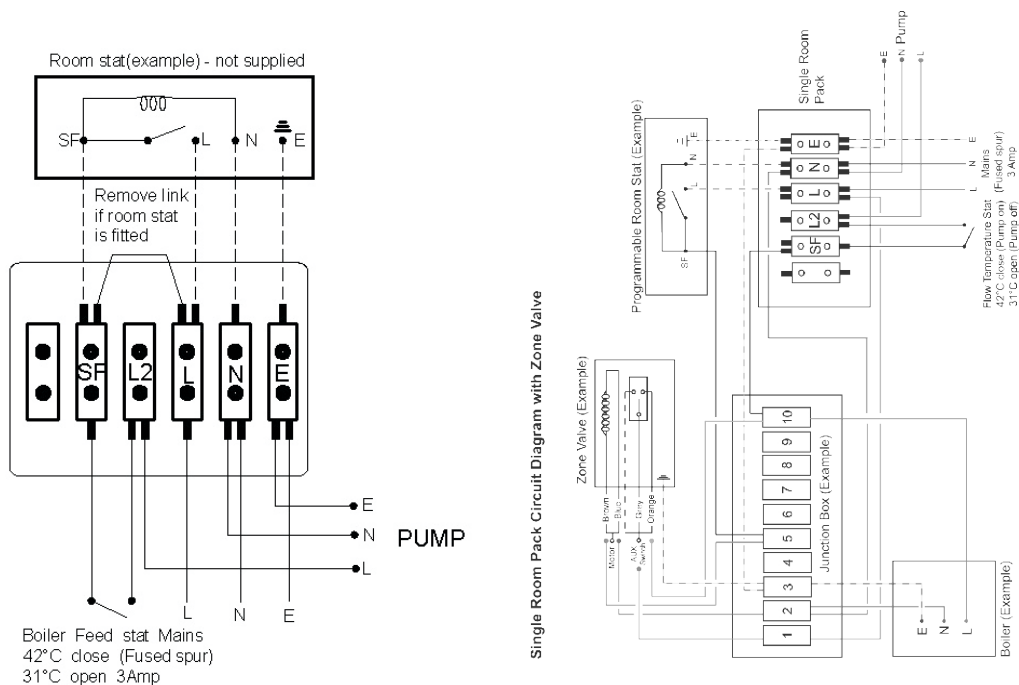

Temperature Settings

The thermostatic blending valve has a temperature setting range between 35°C & 60°C as indicated on the temperature adjustment cap. Initial setting of the thermostatic blending valve (after the heat up/screed drying period) should provide the following flow temperatures.

Screeded floors 40-45°C

Timber floors 55-60°C

These initial settings can then be adjusted to provide comfort. A maximum floor surface temperature of 29°C should not be exceeded (bar wet areas such as bathrooms, 35°C) as this will lead to feelings of discomfort. With timber floor finishes including strip laminate products the maximum floor temperature of 27°C should not be exceeded as this may result in excessive material shrinkage, Adjusting the temperature.

Please ensure that the commissioning of the valve is done under normal operating conditions. The Heatguard UFH blending valve is supplied factory set at 43°C. To alter this setting between 35-60°C proceed as follows:

1. Remove the screw which secures the cap by using the allen key provided then lift the cap off.
2. With both the hot and cold supplies turned fully on and the terminal fitting open, adjust the temperature to the required setting, by using the cap to turn the adjustment spindle.
3. Turn the cap clockwise to decrease or anti-clockwise to increase the temperature.
4. A digital hand-held thermometer should be used to measure the outlet temperature correctly.
5. Once the correct temperature has been set re-fit the cap, ensuring it is secured through the slots on the locking ring so that the valve cannot be adjusted by the end user.

Dimensions

